





iPack C6.5 Lithium Iron Phosphate Battery Residential Energy Storage System User Manual



This document describes the application scenarios, installation, electrical connection, commissioning and troubleshooting of iPack C6.5, a 6.5kWh Battery (hereinafter simply put as battery) for Residential Energy Storage.

Before installing and operating battery, please ensure that you are familiar with product features, functions, and safety precautions as provided in this document.

Warning and caution messages are listed in the document to remind users, installers and maintainers of safe operation.

| Symbol | Description |
|--|---|
|  | Indicates a potentially hazardous situation, if not avoided, could result in serious injury or death. |
|  | Indicates a potentially hazardous situation, if not avoided, may result in minor or moderate injury. |

Contents

| | |
|---|-----------|
| 1 Important Safety Information | 1 |
| 1.1 Warning Label | 1 |
| 1.2 Precautions | 1 |
| 1.3 Responses to Emergencies | 2 |
| 2 Introduction to iPack C6.5 | 3 |
| 2.1 Application Scenarios | 3 |
| 2.2 Product Features | 3 |
| 2.3 Appearance | 4 |
| 2.4 Technical Parameters | 5 |
| 3 Battery Storage and Transportation | 7 |
| 3.1 Safe Storage | 7 |
| 3.2 Safe Transportation | 7 |
| 4 Tools and Protection Equipment | 8 |
| 5 Installation | 9 |
| 5.1 Basic Requirements | 9 |
| 5.2 Install iPack C6.5 | 10 |
| 5.2.1 Wall Mounted Installation | 10 |
| 5.2.2 Floor Standing Installation | 12 |
| 6 Electrical Connection | 13 |
| 6.1 Power Terminals and Network Ports | 13 |
| 6.2 Prepare Cables | 13 |
| 6.3 Connect One Battery | 14 |
| 6.4 Connect Batteries in Parallel | 16 |
| 7 Power on/off Battery | 18 |
| 7.1 Power on Battery | 18 |
| 7.2 Power off Battery | 19 |
| 8 Maintenance | 20 |
| 8.1 Preparation | 20 |
| 8.2 Battery Replacement | 20 |
| 8.3 Firmware Upgrade | 20 |
| 8.4 Troubleshooting | 21 |
| 9 Product Liability | 23 |
| 10 Recycle | 24 |



1 Important Safety Information

1.1 Warning Label

| | | | |
|--|--|---|---|
|  | Do not dispose battery in household trash. |  | Battery is heavy enough to cause severe injury. |
|  | Recyclable. |  | Keep battery away from children. |
|  | Certification in European Union area. |  | Do not reverse polarities. |
|  | Risk of electric shock. |  | Do not expose battery to flame. |
|  | Explosive gas. |  | Operate as specified by the manual. |
|  | Battery may leak corrosive electrolyte. |  | Read the manual before operating. |

Nameplate

Warning Label

| | |
|--|---------------|
|  Lithium Ion Battery IFpP16/122/360/[2P16S]M- 10+50/90 | |
| Model | iPack C6.5 |
| Nominal Voltage | 51.2V |
| Total/Rated Capacity | 128Ah/118Ah |
| Total/Rated Energy | 6.5kWh/6.0kWh |
| Ingress Protection | IP55 |
| Operating Ambient Temperature | -10°C~50°C |
| Max Short Current and Duration | 2200A, 4ms |
| Shanghai Dowell Technology Co.,Ltd. Web: http://www.dowellelectronic.com Email: sales@dowellelectronic.com | |
|  Made in China | |





WARNING

AVERTISSEMENT

1. Do not disassemble or alter the battery in any way.
Ne démontez ni modifiez la batterie en aucune façon.
2. Do not use the battery for purposes not described in its documentation.
N'utilisez pas la batterie à des fins non décrites dans sa documentation.
3. Do not drop, strike, puncture, or step on the battery .
Ne laissez pas tomber, ne heurtez pas, ne percez pas et ne marchez pas sur la batterie .
4. In case of electrolyte leakage, keep leaked electrolyte away from contact with eyes or skin, immediately clean with water and seek help from a doctor.
En cas de fuite d'électrolyte, gardez l'électrolyte qui fuit loin du contact avec les yeux ou la peau, nettoyez immédiatement avec de l'eau et demander de l'aide à un médecin.
5. Do not put the battery into a fire. Do not use it or leave it in a place near fire, heaters, or high temperature sources .
Ne mettez pas la batterie au feu . Ne l'utilisez pas et ne le laissez pas dans un endroit près de feu, de radiateurs ou de sources de températures élevées.
6. Do not submerge the battery in water, or expose it to moisture.
Ne plongez pas la batterie dans l'eau et ne l'exposez pas à l'humidité .
7. Do not allow the terminals to contact exposed wire or metal .
Ne laissez pas les bornes entrer en contact avec du fil ou du métal exposé .
8. The battery is heavy and can cause injury if not handled safely .
La batterie est lourde et peut provoquer des blessures si elle n'est pas manipulée en toute sécurité .
9. Keep out of reach of children or animals. Tenir hors de portée des enfants ou des animaux.























1.2 Precautions

Risks of electrolyte leakage

- Do not subject battery to strong impact.
- Do not crush or puncture battery.
- Prevent battery from falling. In case of fall, turn off the battery immediately and stop using it.
- Do not open or mutilate batteries. Released electrolyte is harmful to the skin and eyes.

Risks of fire

- Do not expose battery to direct sunlight.

- Avoid contact with conductive objects such as wires.
- Keep battery away from fire source, inflammable, explosive and chemical materials.
- Do not dispose of batteries in a fire. The batteries may explode.

Risks of electric shock

- Do not touch battery with wet hands.
- Keep battery away from children and animals.
- A battery can present a risk of electric shock and burns by high short-circuited current.
- Battery installation and wire connection must be operated by professionals.

Risks of damage

- Keep a distance to water source.
- Do not subject battery to high voltage.
- Place battery on a flat surface. Do not place any foreign object on top of battery nor step on battery. .
- Battery-connected PCS should have reinforced insulation.

1.3 Responses to Emergencies

| Event | Description and recommended actions |
|-------------|--|
| Leakage | Inhalation: leave the contaminated area right now. <ul style="list-style-type: none"> • Swallow: induce vomiting. • Contact with eyes: flush eyes with flowing water for 15 minutes. • Contact with skin: wash thoroughly with soap and water. • Immediately seek for medical intervention after taking emergency measures. |
| Fire | Battery may catch fire when heated above 150 °C. Please implement the following actions: <ul style="list-style-type: none"> • Extinguish fire before the battery catches fire. ABC or carbon dioxide extinguisher is recommended. • If the fire is too strong to put out, move battery to a safe place before it catches fire. • If the battery is on fire, evacuate people first before seeking help from professional fire protection personnel. • If battery catches fire during charging, turn off the breaker between battery and PCS when safety can be guaranteed. |
| Wet battery | If battery became wet or has been submerged in water, do not access it. Immediately contact your distributor for technical assistance. |
| Damage | Damaged battery is dangerous and must be handled with utmost care. They are not usable for use and could pose a safety threat to people or property. If battery is suspected to be damaged, stop any operation and return it to distributor. |

2 Introduction to iPack C6.5

The battery is a 6.5kWh LiFePO4 pack. It has a 48V battery module as the main power supply unit which composed of 32 64Ah cells in two parallel and sixteen serial connect (2P16S). Battery coordinates with PV, power conversion system (PCS), Grid, DC Breaker and loads in the residential energy storage system.

2.1 Application Scenarios

The four typical application scenarios are as shown below:

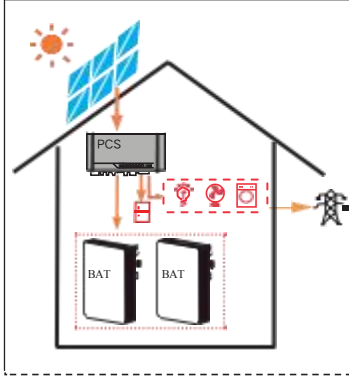

The energy produced by PV is optimized to supply loads. The excess energy is used to charge battery, then export to grid.

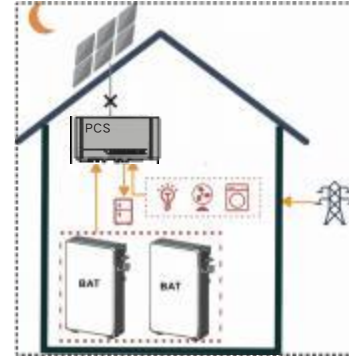

Battery powers loads at night time when there is no PV. If battery energy is insufficient, it can empower loads together with grid.

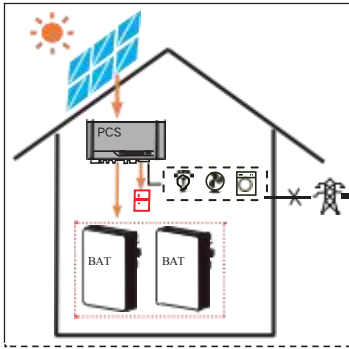

When grid falls, battery and PV can power loads.

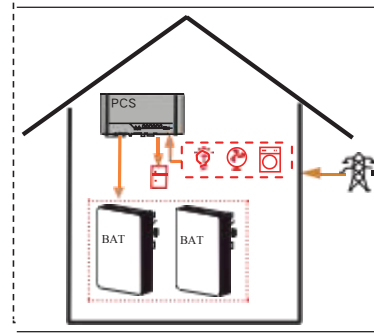

Battery can be charged by grid. Users are suggested to store energy from grid to battery when electricity price is relatively lower.

2.2 Product Features

Compared with normal batteries, the battery is characterized with better charging and discharging performance, longer cycle life and less self-discharging loss. The build-in BMS can monitor battery operation status and alarm timely to avoid operation out of limit. A maximum of 16 batteries can be parallel-connected to expand energy and power of energy storage system. Battery realizes communication with PCS via CAN network port.

- Monitoring:
Detect the voltage and temperature of cell, the voltage and current of battery.
- SOC estimate:
Indicate the precise volume of remaining electricity.
- Alarm:
Alarm when overvoltage, under voltage, overcurrent, over temperature or under temperature occurs.
- Protection:
Protect against over voltage, under voltage, over current, over temperature, under temperature, cell fault and hardware failure.
- Report:

Report alarm messages and operation data to inverter via CAN network ports.

- Parallel connection:
Support a maximum of 16 batteries in parallel connection.
- Power-off triggered by fault:
Battery powers off if level three under voltage, 0V cell or parallel connection failure happens.
- Forced power-off:
When battery does not connect to mains supply, hold POWER button for two seconds and battery powers off.
- Activation:
Input 45V ~ 60V via P+/P- terminals, battery will be activated from off mode to standby status.

2.3 Appearance

The battery is an energy storage unit composed of cells, mechanical parts, battery management system (BMS) as well as power and signal terminals. Product dimensions (unit: mm) and appearance are as shown below:

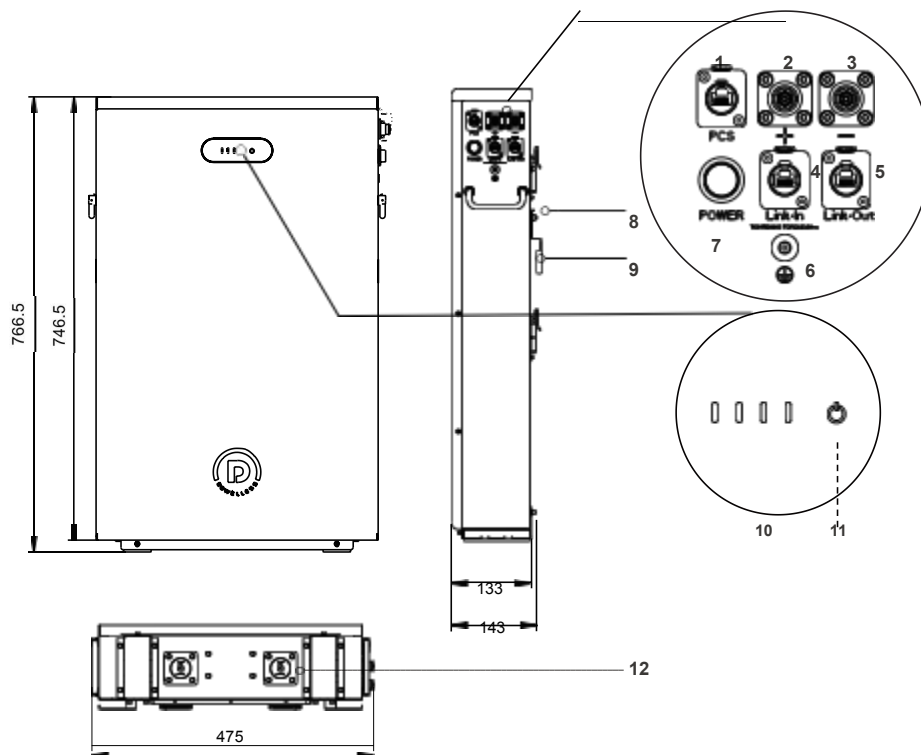

| No. | Label | Name |
|-----|---|--|
| 1 | PCS | Network port for communication with inverter |
| 2 | + | The terminal stands for the Battery cathode output. |
| 3 | - | The terminal stands for the Battery anode output. |
| 4 | Link-In | Input network port for parallel connection |
| 5 | Link-Out | Output network port for parallel connection |
| 6 |  | Grounding terminal |
| 7 | POWER | Power button to turn on/off the Battery |
| 8 | / | Support bracket for wall-mounted installation |
| 9 | / | Limiting notch for wall-mounted installation or Anchor for floor-standing installation |
| 10 | RUN/ALM | LED indicator of running status and alarm |
| 11 | SOC | LED indicator of battery SOC |
| 12 | / | Safety vent |

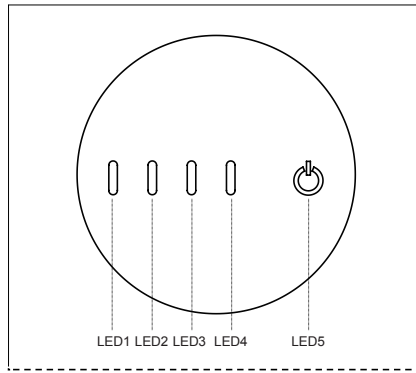

Table 2-1 LED Indication

| Battery Status | PACK Information | SOC | | | | Bi-colour |
|---------------------|------------------|------|------|------|------|-----------------|
| | | LED1 | LED2 | LED3 | LED4 | LED5 (BLUE/RED) |
| charge | 0%-25.0% SOC | ▪ | | | | • |
| | 25.1%-50.0% SOC | ▪ | ▪ | | | • |
| | 50.1%-75.0% SOC | ▪ | ▪ | ▪ | | • |
| | 75.1%-99.9% SOC | ▪ | ▪ | ▪ | ▪ | • |
| | 100% SOC | • | • | • | • | • |
| Discharge & Standby | 100%-75.1% | • | • | • | • | • |
| | 75.0%-50.1% | • | • | • | | • |
| | 50.0%-25.1% | • | • | | | • |
| | 25.0%-0% | • | | | | • |

• LED On ■ LED flickers

2.4 Technical Parameters

| No. | Items | Specifications |
|-----|-------------------------------------|--|
| 1 | Total Capacity/ Energy | 128Ah/6.5kWh |
| | Rated/Usable Capacity/Energy | 118Ah/6.0kWh |
| 2 | Nominal Voltage | 51.2 V |
| | Operating Voltage | 44.8~57.6V |
| 3 | Max. continuous charging current | -10°C≤T<0°C: 21.3A 0°C≤T<5°C: 32A 5°C≤T<15°C: 64A 15°C≤T<45°C: 104.2A 45°C≤T<50°C: 64A 50°C≤T<55°C: 32A |
| 4 | Max. continuous discharging current | -10°C≤T<0°C: 21.3A 0°C≤T<45°C: 104.2A 45°C≤T<50°C: 85.3A 50°C≤T<55°C: 32A |

| | | |
|----|--|---|
| 5 | Peak Charging/Discharging Current | 125A/60s |
| | Max. Charging power | 5kW (15°C~45°C) |
| | Max. Discharging power | 5kW (0°C~45°C) |
| | Peak Charging/Discharging power | 6.9kW/60s (SOC≥20%, 25°C) |
| 6 | Operating ambient temperature | -10°C~50°C |
| | Recommended operating temperature | 15°C~30°C |
| 7 | Storage conditions | Temperature: -20°C~+ 45°C, 6 months; -30°C~ -20°C, 45°C~ 60°C, 7 days; (for shipping state) Humidity: 5%-95%RH Within 6 month after each charge |
| 8 | RTE | 94%, 0.2C charge/discharge 25°C |
| 9 | DOD | 93% |
| 10 | EOL | 60% SOH, 10 years |
| 11 | Cooling | Natural cooling |
| 12 | Ingress protection | IP55 |
| 13 | Max. operation altitude | ≤2000m |
| 14 | Cell safety certification | IEC62619 |
| 15 | Battery safety certification | CE |
| 16 | UN transportation test standard | UN38.3+PI965 (Sea) |
| 17 | Environmental protection certification | RoHS, REACH |
| 18 | Communication with PCS | CAN |
| 19 | Parallel connection | Maximum 16 batteries |

Unless otherwise specified, all tests stated above are conducted at below conditions:

Temperature: 25±2°C;

Humidity: 5RH-95%RH

3 Battery Storage and Transportation

3.1 Safe Storage

| Life | Temperature | Humidity |
|----------|--------------------------------|------------|
| 7 days | -30°C to -20°C or 45°C to 60°C | 5%RH-95%RH |
| 180 days | -20°C to 45°C | 5%RH-95%RH |

If the battery is not used for more than 1 week, store it in accordance with the requirement for storage conditions.

- Place battery according to signs on packing case.
- Do not put battery upside down or sidelong.
- Store batteries in a place free from direct sunlight and rain.
- Keep batteries at least two meters away from a heat source (such as a radiator).
- Avoid contacting with corrosive and organic substances (including gas exposure).
- Batteries with deficiencies should be separated from normal batteries by setting wall between or placing in difference fire protection zones.
- Ambient temperature ranges between -30°C to 60°C during the first seven days, and ranges between -10°C to 45°C within six months. Relative humidity ranges between 5%RH-95%RH.
- Keep the storage area dry, clean and well ventilated.

In case of storage over 6 months, batteries should be recharged in the following steps:

1. Identify batteries that need recharging;
2. Ensure batteries in power-off mode. Refer to Quick Guidance to complete wire connection;
3. Set "CV=56.8V, CC=16A (5°C-45°C)";
4. Recharge until LED2 flicks.

3.2 Safe Transportation

Battery has cleared UN38.3 (Section 38.3 of the seventh Revised Edition of the Recommendations on the Transport of Dangerous Goods: Manual of Tests and Criteria) and SN/T 0370.2-2009 (Part 2: Performance Test of the Rules for the Inspection of packaging for Exporting Dangerous Goods). The battery is classified as class 9 dangerous goods, and is subject to land and water transportation. It is mandatory to report to the airline company and obtain approval before air transport.

- Before transportation, hold POWER button for two seconds and five LED lights flicker for three times to power off battery.
- During transportation, keep battery flat, do not have battery stand on or lean against the floor to avoid possible crash.
- Maintain temperature between -20°C to 45°C during the transportation.
- Prohibit mixing up with explosive, inflammable or toxic objects.
- Use van-type vehicle including container and metallic van-type vehicle. Platform vehicle and convertible are prohibited.
- Do not pile up foreign objects on the top of battery. Four batteries at most can be piled up.
- Maintain original packaging and keep labels complete and recognizable.
- Prevent from direct sun exposure, rain, condensation and mechanical damages.

4 Tools and Protection Equipment



Drill



Tape measure

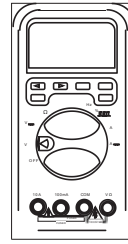

Multi-meter



Mark pencil

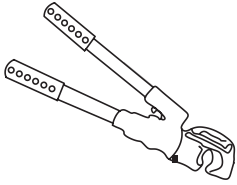

Hydraulic plier

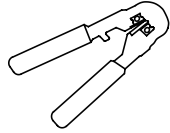

Wire crimper

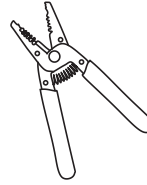

Wire stripper

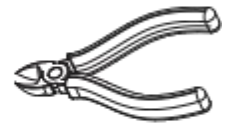

Wire cutter

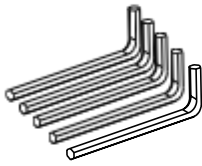

Hex key #5



Insulated gloves

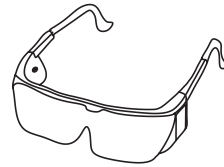

Safety goggles



Rubber boots



Screwdriver

5 Installation

5.1 Basic Requirements

Battery can be installed indoors or outdoors. Ensure the following conditions are satisfied:

- A deviation of $-5^\circ \leq \theta \leq 5^\circ$ is allowed for both installation against wall and floor.
- Please refer to figures below (✓ means acceptable installation and X unacceptable).

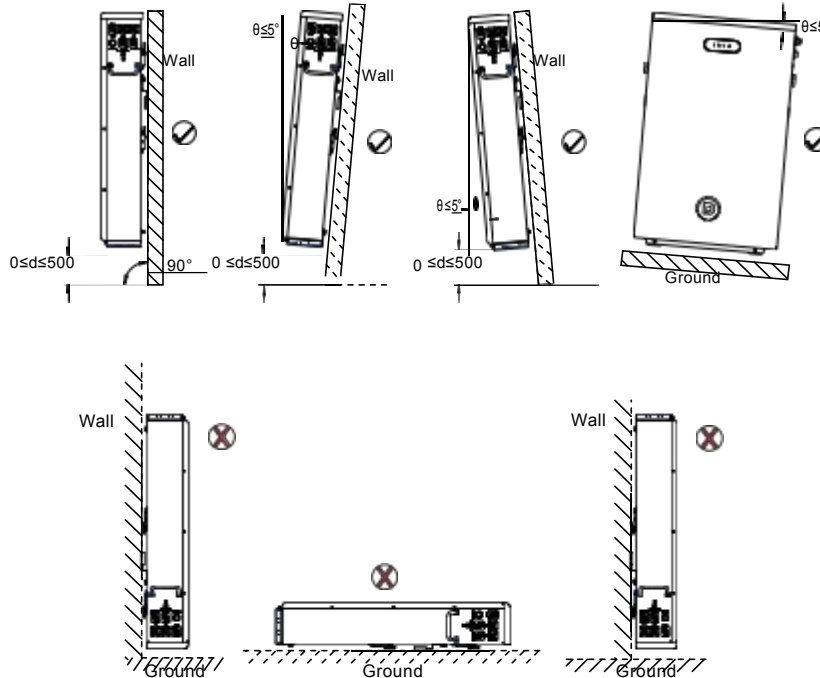

CAUTION

Do not place the battery upside down nor keep it flat as above.

- It is recommended to build sunshade & rain shelter to avoid direct exposure to sunlight and rain.

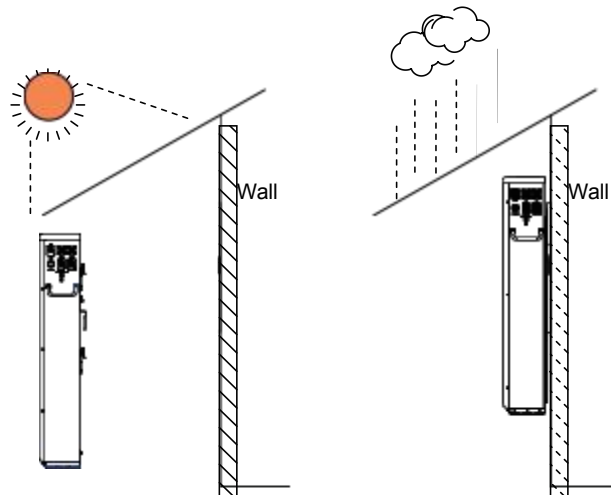

CAUTION

- Keep the dirt or dust at a minimal level;
- Do not install battery in a place where flood frequently occurs;
- Do not install battery in highly humid area such as bathroom;
- Ensure direct contact between battery shell and ambient air. Do not cover or shield battery to avoid poor cooling.

5.2 Install iPack C6.5

Pre-installation Check

- Check exterior package
Before opening package, check for damages like holes, cracks or other traces on exterior packing case. If any abnormality is detected, do not open the package and contact your distributor.
- Check deliverables
After opening package, check if deliverables are complete. If there is any part missing or damaged, please contact your distributor.

Accessory list

| Accessories | |
|----------------|---|
| iPack C6.5 | 1pcs |
| Fastenings | M8 expansion screw 9pcs M8*H60 anchor 9pcs M6 screw 1pcs Bubble level 1pcs |
| Terminator | 2pcs |
| Manual | 1pcs |
| Bracket | 1pcs |
| Warranty Card | 1pcs |
| Accessory List | 1pcs |

5.2.1 Wall Mounted Installation

Step 1. Confirm installation spot.

At least two persons participate the installation.

1. One person places the bracket on wall and ensures the bubble level horizontal;
2. The other person marks spots of screw driving.
3. After confirming the spots to drive screws, put down the bracket.

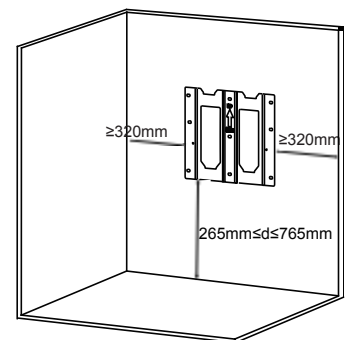

- The weight capacity of wall should exceed 4 times weight of battery.
- Installer should consider the specific wall shape before choosing four drilling spots.

Step 2. Fix bracket to wall.

1. Choose alloy drill bit with a diameter of 12 mm and install it to a drill.
2. Drill in the spots that have been located in step 1 and have at least 60mm drilling depth.
3. Clean the dust and drive expansion tube into the hole.
4. One person puts the bracket on wall and keep bubble level horizontal.
5. The other person drives M8 screw through the bracket into hole till the end.

6. There are two spot drilling proposals available:
7. For a wall with its main supporting beams at a distance of 16 inches, adopt the first drilling plan.
8. For a wall with its main supporting beam at a distance of 24 inches, adopt the second drilling plan.

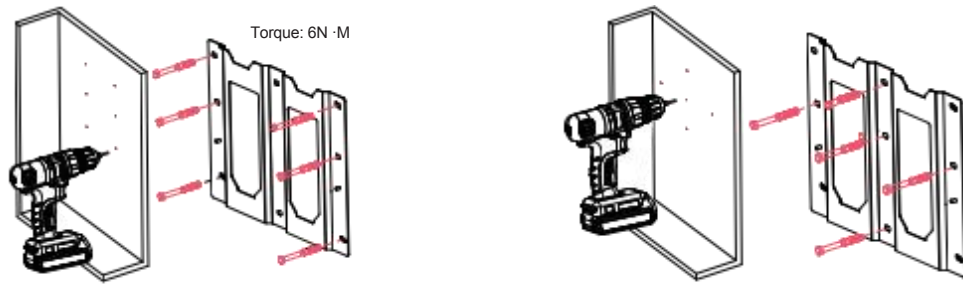

Step 3. Fix battery on bracket.

1. Rotate the left latch leftward and the right latch rightward until they keep perpendicular to the battery.
2. Install battery from the top down and lock the connection part of battery with the support plate of bracket.

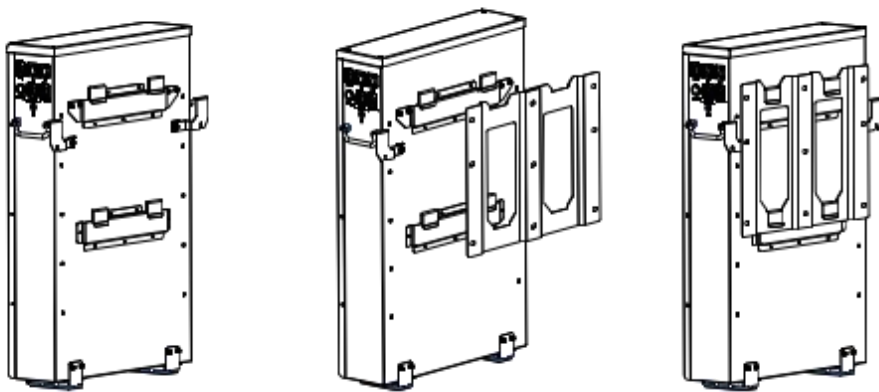

3. Rotate the left latch rightward until the notch locks limiting pin, and rotate the right latch leftward until the notch locks limiting pin too.

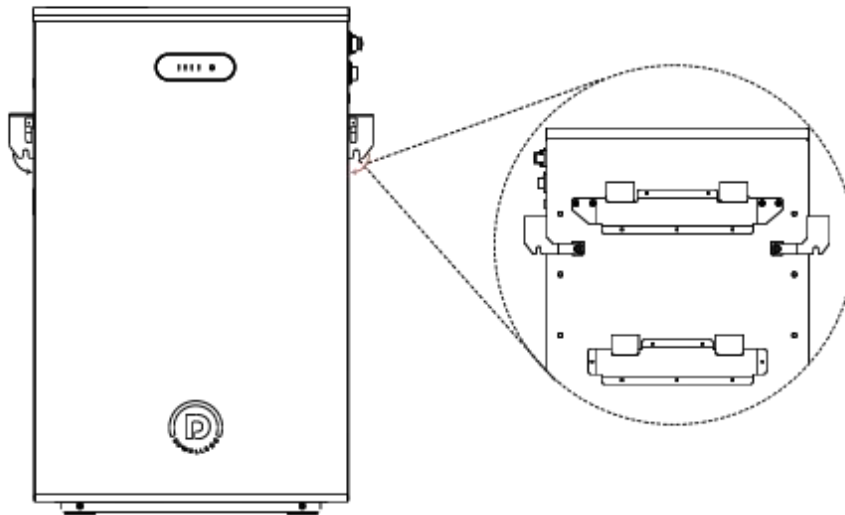

Step 4. Confirm that the battery is installed properly.

1. Visually inspect the two upper joints to guarantee a stable connection between battery and bracket.
 2. Pull the lower part of battery away from wall and ensure that the battery cannot be moved at all.
- Otherwise, please connect the battery and bracket again until confirming a fixed connection.



CAUTION

- Leave a minimum clearance of 133 mm before the front surface of battery.

5.2.2 Floor Standing Installation

Step 1. Confirm installation spot.

1. Place battery in the to-be installed area.
2. Rotate the left latch leftward and the right latch rightward until they are perpendicular to the battery.

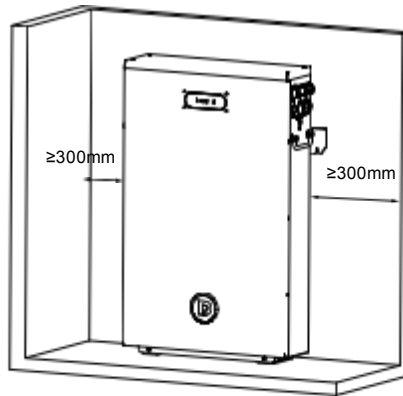

3. Use pencil to mark where the notches of two latches are and confirm the two drilling spots. Move battery away.

Step 2. Install battery.

1. Choose an alloy drill bit with a diameter of 12 mm and install it in the drill.
2. Drill two holes in the spots that have been confirmed in step 1.
3. Keep the drilling depth as least 60mm.
4. Clean the dust and drive expansion tube into hole.
5. Move battery pack to the place confirmed in step 1.
6. Drive M8 screw through notch of latch into wall.

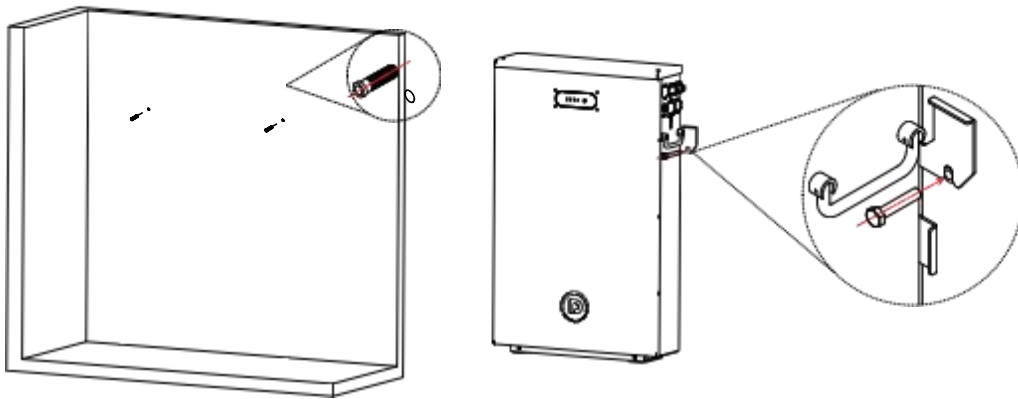

6 Electrical Connection

iPack C6.5 can work in single mode and parallel mode. To make the battery work properly, follow the instructions below to correctly connect it.

This chapter describes how to make cable and wires, and connect one battery and multiple batteries. If you have finished-cable and wires already, skip Section 6.1 and 6.1. Otherwise, read 6.1 and 6.2 carefully.

6.1 Power Terminals and Network Ports

| Terminal | Model | Cable Cross-Section |
|---|------------------------------|---------------------|
| + | Amphenol, C10-752799-010 | 25 mm ² |
|  | Amphenol, C10-752799-110 | 25 mm ² |
| - | M6 HEX socket head cap screw | 16 mm ² |

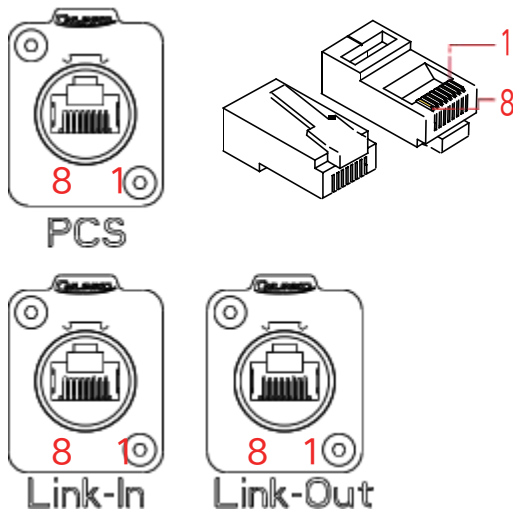
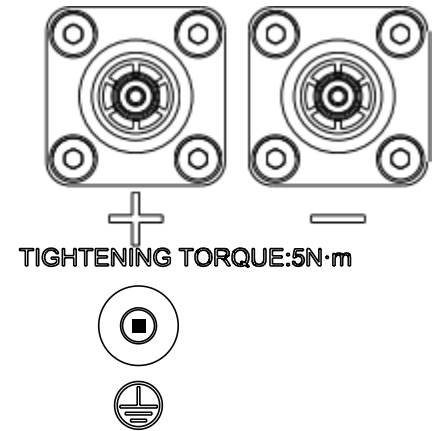

| No. | PCS | Link-Out | Link-In |
|-----|-------------|-------------|---------------|
| 1 | PCS-RS485-B | PACK-CANH | PACK-CANH |
| 2 | PCS-RS485-A | PACK-CANL | PACK-CANL |
| 3 | NC/GND-ISO | Encode-OUT+ | Encode-IN+ |
| 4 | PCS-CANH | GND-ISO | GND-ISO |
| 5 | PCS-CANL | Slave-Last | Master-Select |
| 6 | NC/GND-ISO | GND-ISO | GND-ISO |
| 7 | PCS-WAKE- | GND-ISO | NG/GND-ISO |
| 8 | PCS-WAKE+ | COM-WKP-OUT | COM- WKP-OUT |

6.2 Prepare Cables

Step 1. Make power cables.

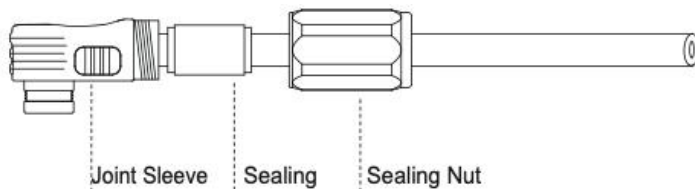

- Strip cable sheaths for 20 ± 0.5 mm and insert sealing and sealing nut along the cable.

Orange: positive cable

Black: negative cable

- Insert the copper wires all into the joint sleeve.

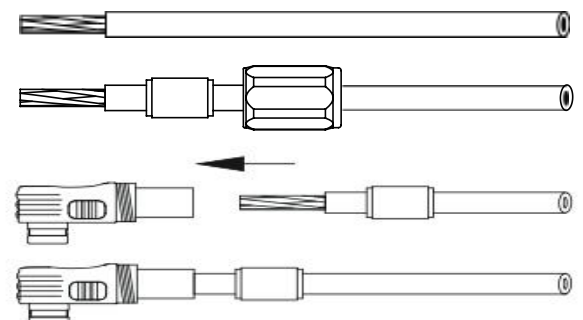

3. Press connecting part with a hydraulic clamp.

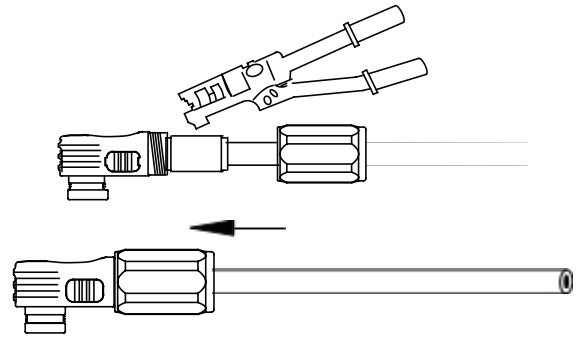

4. Tighten up sealing, sealing nut and joint sleeve.

Step 2. Make network cables.

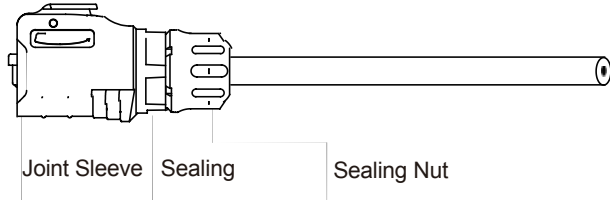

1. Strip cable sheaths for $15 \pm 0.5\text{mm}$ first and insert sealing and sealing nut along the cable.

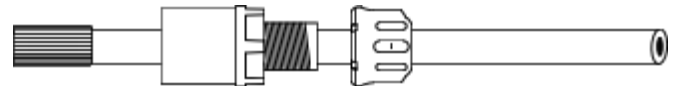

2. Insert eight wires into RJ45 plug.
Network cable adopts standard 8-core cable.
Ensure all wires stay well aligned.

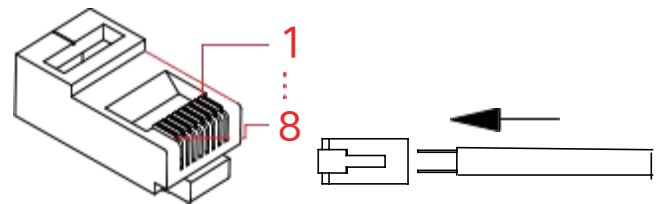

For Network Cable B that is used for parallel connection, ensure that the wire colours are pin-to-pin consistent at two ends.

3. Crimp the RJ45 plug with a wire crimper.

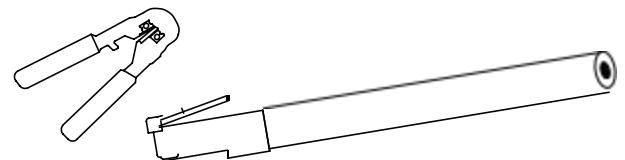

4. Connect RJ45 plug with joint sleeve, and tighten up sealing, sealing nut and joint sleeve.

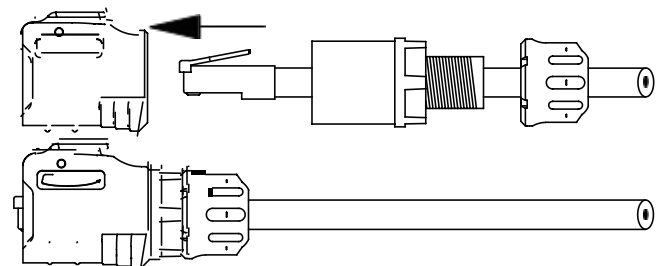

When making Network Cable B, process the other end in the same way.

6.3 Connect One Battery

Step 1. Measure battery voltage with a multi-meter and ensure the voltage output is 0V under power-off mode.

Step 3. Ground the battery.

Fasten the grounding wire to the terminal of the battery with an M6 screw.

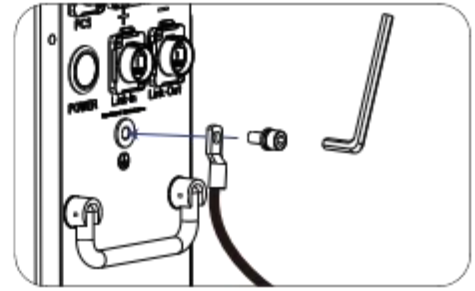

Step 4. Connect network cable.

1. Plug one end of Network Cable A into the PCS port of the battery and the other end into the network port of PCS.
2. Insert two terminators into **Link-In** and **Link-Out** of the battery respectively.

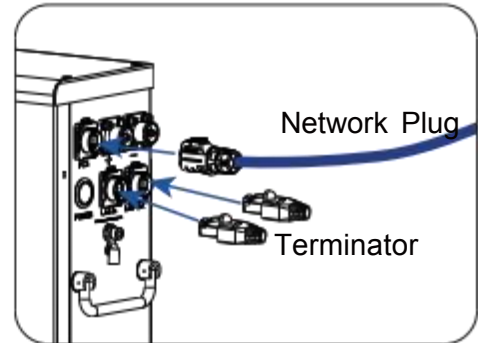

Step 5. Connect power cables.

Plug one end of the power cables into DC breaker, and plug the other end into the battery terminals.

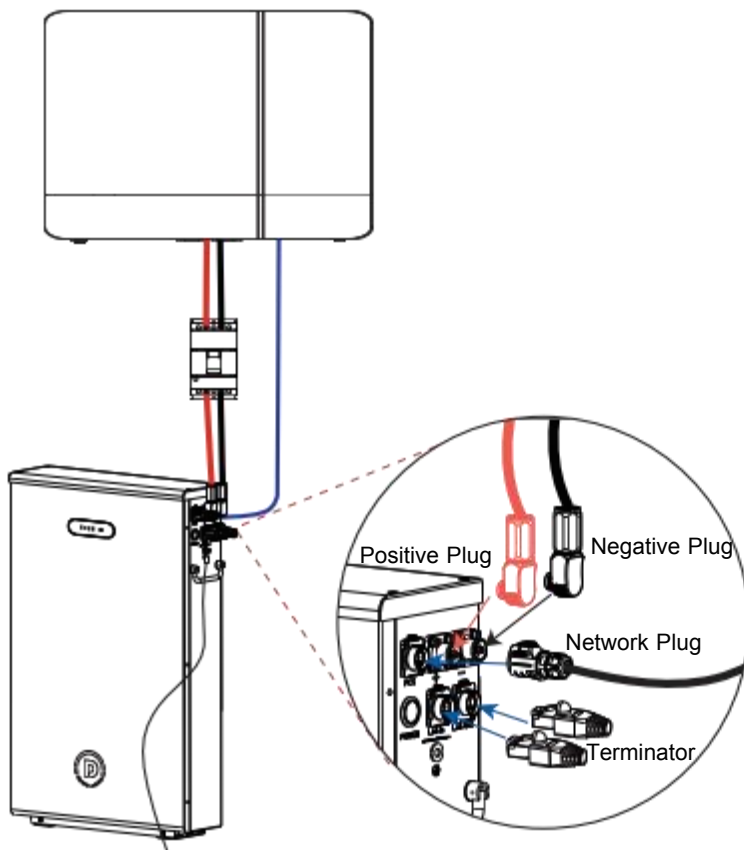
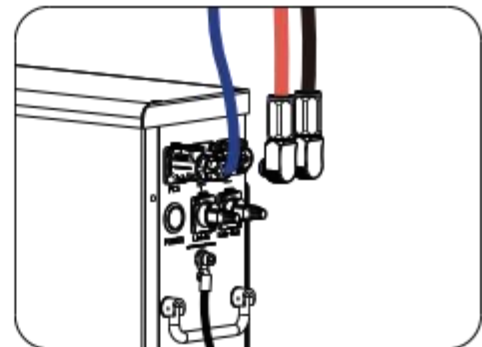

WARNING

- A manually operating breaker should be installed between battery and PCS to control the main circuit during installation, wire connection and maintenance.
- The breaker can be operated manually without using any tool and should be located near the battery.
- The distance between battery and the breaker should comply with local regulations.

6.4 Connect Batteries in Parallel

A maximum of eight batteries can be connected to one PCS in parallel.



Ensure batteries in parallel connection are from the same batch, same model and same manufacturer. Do not mix an old battery with a new battery. Batteries undergone less than 300 cycles are defined as new batteries.

Batteries can be connected in parallel in the following way:

Step 1. Confirm that the voltage difference is not greater than 1V.

1. Power on the batteries without load and use a multi-meter to measure their voltages.
2. If the voltage difference is greater than 1V, charge the battery with lower voltage.
3. Power off the batteries.

Step 2. Fasten ground screws and grounding wires for all batteries.

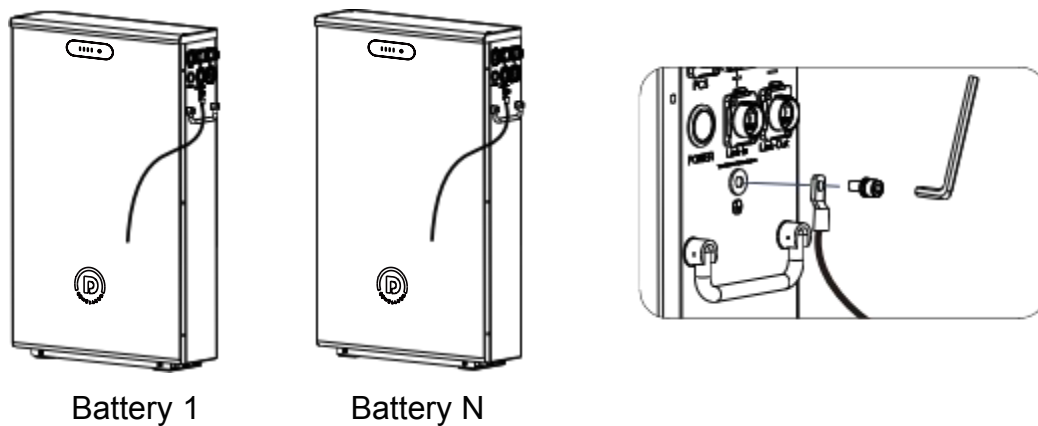

Step 3. Insert network cables into battery terminals.

1. Connect the **PCS** port of Battery 1 to the gateway by using network cable A.
2. Connect the **Link-Out** port of Battery 1 to the **Link-In** port of Battery 2 by using network cable B. The process goes on until the last battery is connected.
3. Insert two terminators into the **Link-In** port of Battery 1 and the **Link-Out** of Battery N respectively.

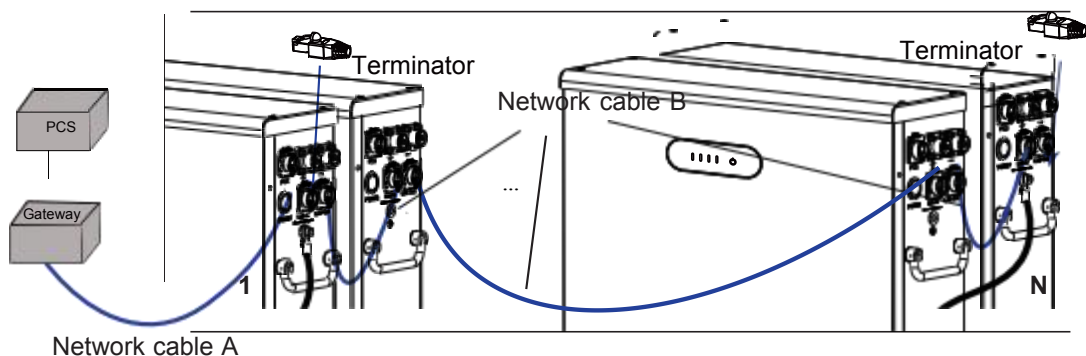

Step 4. Insert power cables into battery terminals.

1. Measure the positive and negative terminal blocks of each battery with a multi-meter, and ensure the voltage outputs under off mode and all 0V.
2. Plug all positive cables in positive junction box and negative cables in negative junction box.
3. Plug one end of positive and negative power cables into DC breaker.
4. Plug the other end of power cables into battery terminals.
5. Connect DC Breakers with one PCS.

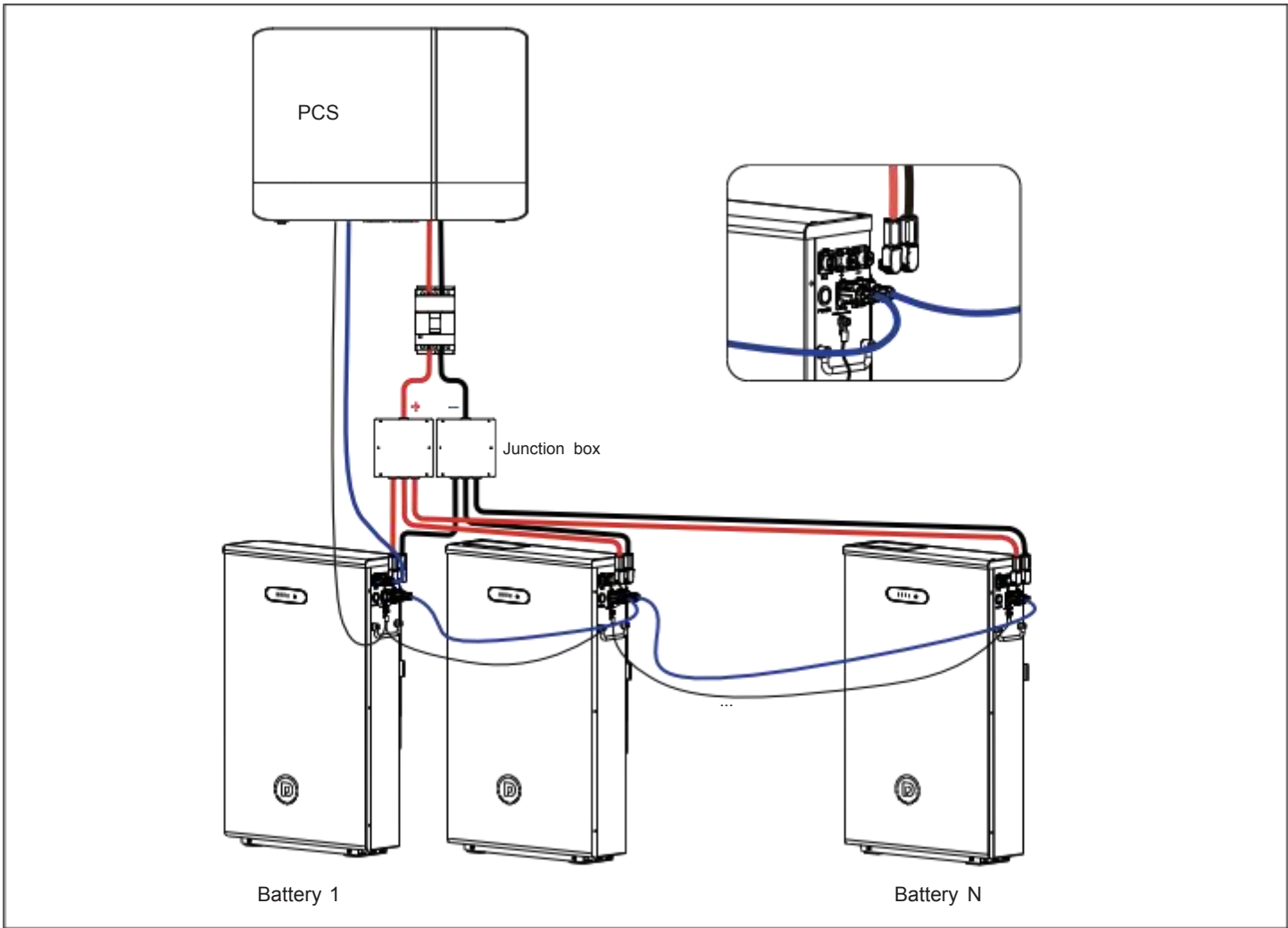

7 Power on/off Battery



WARNING

When operating or maintain the battery module, please strictly follow the safety instruction below:

- You must be a technician who goes through technical training and obtains certificates in compliance with local laws and regulations.
- Please stand on dry insulating objects and do not wear metal objects such as watches, rings and necklaces during operation.
- Use insulating tools and wear protective devices.
- Do not contact with two charged positions with a potential difference.
- Hang a prohibition sign that stops people approaching the battery.
- Measure battery voltage with a multi-meter and ensure voltage output in off mode is 0V.
- If any abnormality is detected, immediately power off the battery. Proceed only after causes are confirmed.

7.1 Power on Battery

Battery can be powered on by power button and activation signal from PCS. This section describes how to power on single battery and batteries in parallel.

By Button

Power on battery by button in the following way:

1. Push the breaker that is connected with battery to ON.
2. Hold the POWER button for two seconds.

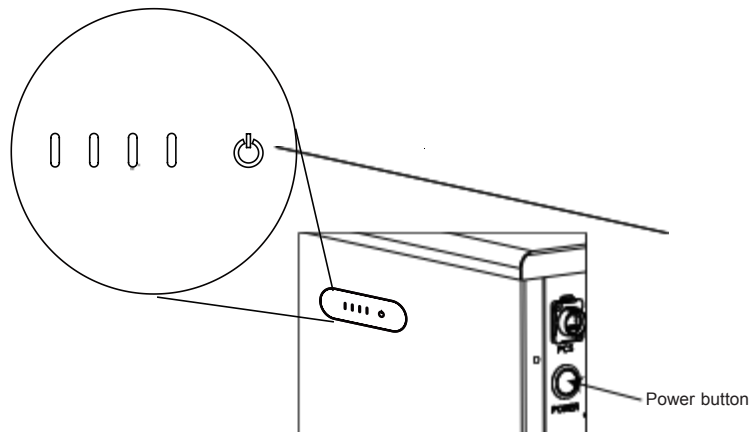

RUN and SOC indicators turn on and indicate correct state. The battery is powered on successfully.

If ALM indicator lights up in red, a failure occurs. Troubleshoot the issue and power on the Battery again.

By Activation Signal

Power on one battery by activation signal in the following way:

1. Switch on the PCS and check the HMI screen of PCS to ensure that the PCS is empowered by PV or mains.
2. Push the breaker that is connected with battery to ON.
3. Send an activation voltage or wakeup signal through the PCS to the battery.

RUN and SOC indicators turn on and indicate correct state. The battery is powered on successfully.

If ALM indicator lights up in red, a failure occurs. Troubleshoot the issue and power on the battery again.

7.2 Power off Battery

- Hold the POWER button of any battery for two seconds.
Five LED lights will flicker for three times, and battery turns off.
- Turn off the inverter. Communication will drop for 60 minutes.
Before five LED lights flicker for three times and battery turns off.
- Activate the Timing Power function and battery will power on automatically after 24-hour standby status.

8 Maintenance

8.1 Preparation

- Battery replacement should be conducted by professionals.
- Prepare tools like safety gloves, cross head driver and socket wrench.
- Ensure undamaged appearance and complete accessories of new battery.
- Do not change battery in rainy or stormy days.
- Open breaker and power off old battery;
- Confirm wire connection of new battery, close breaker and power on new battery.

8.2 Battery Replacement

1. Wear safety gloves.
2. Switch off breaker, hold POWER button for two seconds to power off battery.
3. Unplug power cables and network cable from battery terminals.
4. For wall-mounted battery: rotate both latches upward. Two persons lift up battery off bracket.

For floor-standing battery: unscrew expansion screws with a crosshead screwdriver, rotate latches upward and move battery.

5. Two persons move battery via handles into packing case and transport battery to a designated repair site.
6. Install new battery.

8.3 Firmware Upgrade

Step 1. Install software

1. Choose file "BMS Installation package.zip" and decompress it.
2. Enter "BMS Installation package \Volume", double click "setup.exe" and run it.

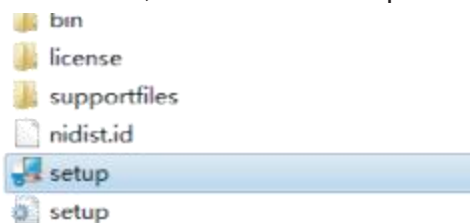

3. Execute the default configuration until completing the installation.

Step 2. Make sure the battery stay in IDLE mode or battery relays cut off.

Step 3. Connect computer and the HOST network port on battery with CANalyst-II.

Step 4. Upgrade

1. Choose "Upgrade" as shown in the below figure.



2. Choose "CANalyst-II" for device type and "Extend" for Frame Type, set "500Kbps" baud rate. Keep other default parameters. Click "OK" .

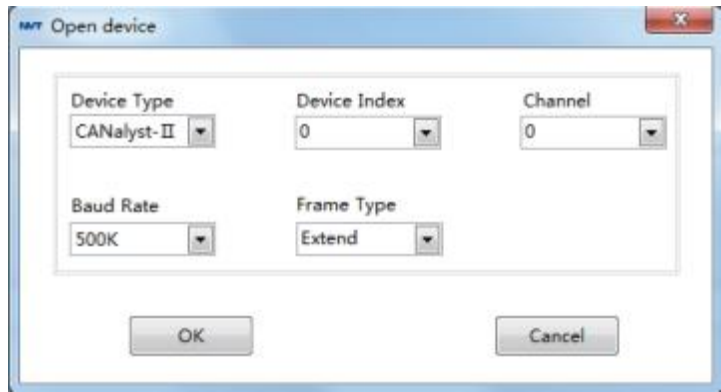

3. Choose target upgrade file and click “Start to Upgrade”.
Upgrade succeeds when progress bar reaches 100%.



8.4 Troubleshooting

| Battery Status | Battery Information | SOC | | | | Bi-colour BLUE/RED | Remark |
|----------------|---------------------|------|------|------|----------|--------------------|--|
| | | LED1 | LED2 | LED3 | LED4 | LED5 | |
| Remote | | / | / | / | / | / | LED5 depending same as the normal status |
| Boot load | | . | . | . | . | . | 2HZ |
| Starting | Master/Slave | . | . | . | . | • | Master |
| | | / | / | / | . | • | Slave 1 |
| | | / | / | . | / | • | Slave 2 |
| | | / | / | . | . | • | Slave 3 |
| | | / | . | / | / | • | Slave 4 |
| | | / | . | / | . | • | Slave 5 |
| | | / | . | . | / | • | Slave 6 |
| | | / | . | . | . | • | Slave 7 |
| | | . | / | / | / | • | Slave 8 |
| | | . | / | / | . | • | Slave 9 |
| | | . | / | . | / | • | Slave 10 |
| | | . | / | . | . | • | Slave 11 |
| | | . | . | / | / | • | Slave 12 |
| | | . | . | / | . | • | Slave 13 |
| | | . | . | . | / | • | Slave 14 |
| / | / | / | / | • | Slave 15 | | |

| | | | | | | | | |
|---------------------------|--|-------------|---|---|---|---|---|---------------|
| Application Mode checking | Parallel or single application mode checking success | SOC Display | | | | | . | Blink 5 times |
| | Waiting for parallel connection of PACK to power circuit | SOC Display | | | | | . | 1Hz |
| Fault | Three-Level Cell Over Voltage | / | / | / | . | . | | |
| | Three-Level Cell Under Voltage | / | / | . | / | . | | |
| | Three-Level Over Temperature | / | / | . | . | . | | |
| | Three-Level Under Temperature | / | . | / | / | . | | |
| | Three -Level Over Current (charge or discharge) | / | . | / | . | . | | |
| | Three -Level Under SOH | / | . | . | / | . | | |
| | Internal communication | / | . | . | . | . | | |
| | External communication | . | / | / | / | . | | |
| | Parallel ID coding failure | . | / | / | . | . | | |
| | FUSE fault | . | / | . | / | . | | |
| | Parallel connection failure | . | / | . | . | . | | |
| | Reserved | . | . | / | / | . | | |
| | Reserved | . | . | / | . | . | | |
| Reserved | . | . | . | / | . | | | |
| BMS fault | . | . | . | . | . | | | |

9 Product Liability

DOWELL is not responsible for the incident caused by not obeying the Manual. Before using the battery, you should read the specifications, safety information and operation instructions carefully to learn its application method and scenarios. If the product or accessories are damaged by incorrect using method, wrong circuit connection, incorrect data settings, or working beyond limit defined in the Manual, Dowell does not provide any warranty or assume any accountability for the injuries or loss.

10 Recycle

Lithium iron batteries are recyclable, valuable resources and should be recycled according to the local laws or regulations. Do NOT throw your battery into household waste.

For information on used batteries, contact the place of purchase or your battery distributor.